

5L UN ECO III STACKABLE

EC DESIGN REG No: 007986732-0005/06

Material	HM-HDPE
O/All Dimensions	260 x 193 x 146mm
UN Approved	Group II Freestanding
Weight	250g
Brimful Capacity	5,500ml +/- 25
Colours Available	Yes, available on request
Decoration Label Area	Yes (h) 150mm x (w) 145mm
Manufacturing Base	UK
Widely Recycled	 PE

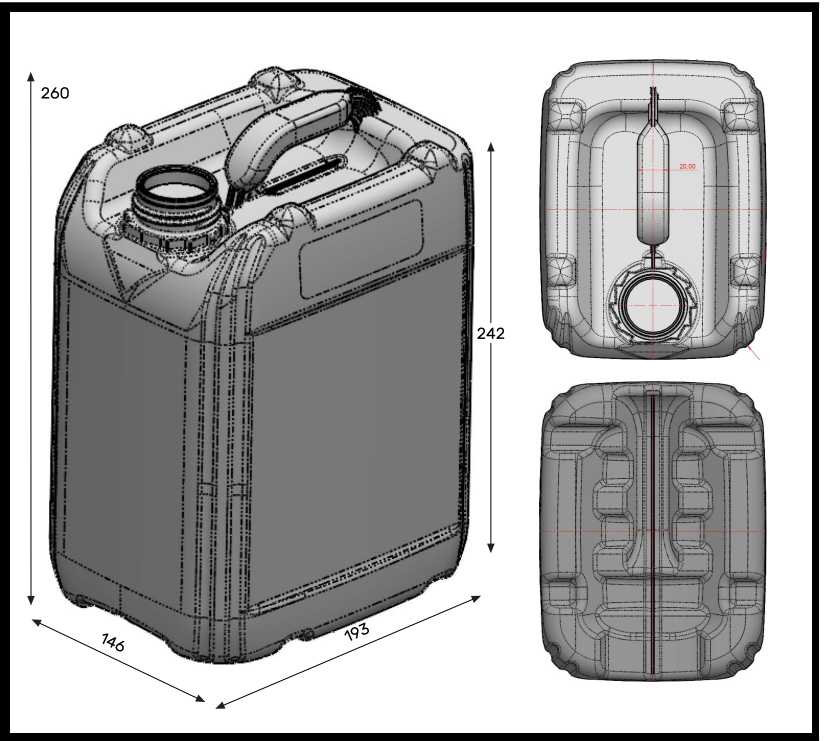

NECK DETAILS

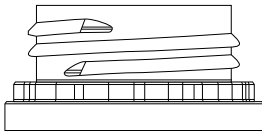

Neck	DIN 51mm
Closures	51mm TE, 51mm Vented, 51mm Anti-glug
Closing Torque	10-15nm
Sealing Options	Available on request

All Nexus containers are manufactured in facilities registered to ISO9001:2000 Quality Management Systems and BRC/lop technical standards for food packaging manufacturers (Category B).

These containers are suitable for food contact and meet the requirements of the Food Safety Act, Plastic Materials in Contact with Food regulations and all other applicable legislation, including global migration limits with model foods for 10 days up to 40 °C. Test reports and certificates are available on request. They meet the requirements of the Packaging Essential Requirements regulations including the limits of heavy metal and noxious substances content. Test reports and certificates are available on request.

Nexus can assist with customers' legislative requirements and use a UKAS accredited laboratory for conducting UN dangerous goods carriage tests. Full details on request. We offer full technical and practical advice on the use of our containers.

PACKING CONFIGURATION

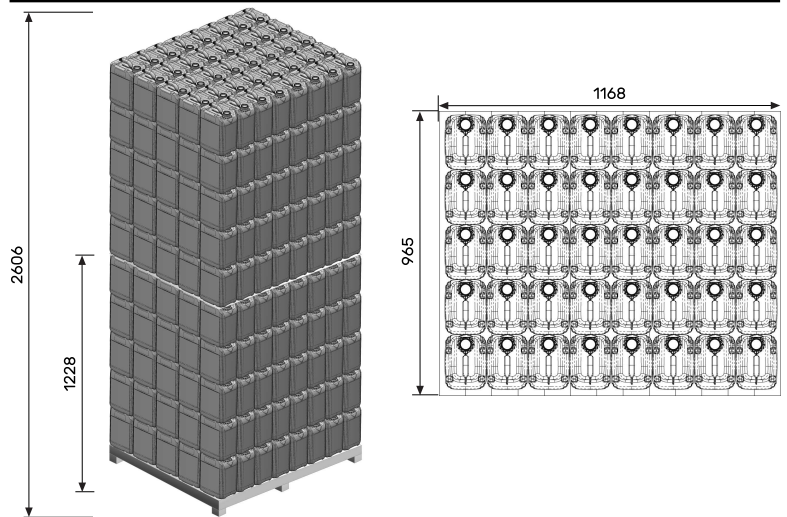

Pack Type	Palletised & Heat Sealed
Pallet size	1 x 1200 x 1000mm
Units Per Pallet	400 per lift (height: 2606mm) 2 x shrink-wrap packs of 200
Units per Full Load	40 per layer (no layer card/tray) 10,400 without caps. 10,000 with caps

This data sheet is for reference only. Full specification can be provided on request. Values indicated may vary within permitted tolerances. Suitability for purpose is subject to user verification.

Nexus Packaging Ltd.

Nexus House, Wilson Business Park, Queen Elizabeth Avenue, Hillington Park, Glasgow G52 4NQ.
+44 (0)141 429 2525 | admin@nexpack.co.uk | www.nexpack.co.uk

